

- For continuous non-contact level measurement
- Suited to level measurement of various liquid and bulk-solid materials
- Outstanding contrast OLED display
- Easy adjustment without measured material
- Quick view measured values on the display
- Xi version for usage in explosive areas
- Current output (4 ... 20 mA) with HART communication protocol



The **ULM[®] ultrasonic level meters** are compact measurement devices including an electroacoustics converter, central processor unit and display module. Using the electroacoustics converter, the level meters transmit the sequence of ultrasonic pulses that spread towards the surface level. The converter recuperates reflected acoustic waves that are subsequently processed in the electronic module. The intelligent evaluation block filters out interfering signals, compares the cleaned received signal with the false reflection map (e.g. from mixers, ladders, reinforcement etc.) and selects a suitable reflection (echo). Based on the period during which the individual pulses spread towards the surface level and back and based on the measured temperature in the tank, the instant distance to the surface level is calculated. According to the level height, the level meter output is set and the measured value is displayed on the display.

The level meters are suited to level measurement of various liquid materials, sewerage waters, mash and paste materials, suspensions in closed or open vessels, sumps, reservoirs and open channels. In case the level of bulk-solid materials is measured, the measurement range is reduced. We recommend to consult the use with the manufacturer.

FEATURES OF VARIANTS

- **ULM-70_-02-I** **Measuring range from 0.15 m to 2 m**, plastic PVDF transmitter, mechanical connection with thread G 1".
- **ULM-70_-06-I** **Measuring range from 0.25 m to 6 m**, plastic PVDF transmitter, mechanical connection with thread G 1 ½".
- **ULM-70_-10-I** **Measuring range from 0.4 m to 10 m**, plastic PVDF transmitter, mechanical connection with HDPE polyethylene flange (version "N") or aluminium alloy flange (version "Xi").
- **ULM-70_-20-I** **Measuring range from 0.5 m to 20 m**, plastic PVDF transmitter, mechanical connection with aluminium alloy flange.

DIMENSIONAL DRAWINGS

ULM-70_-02-I

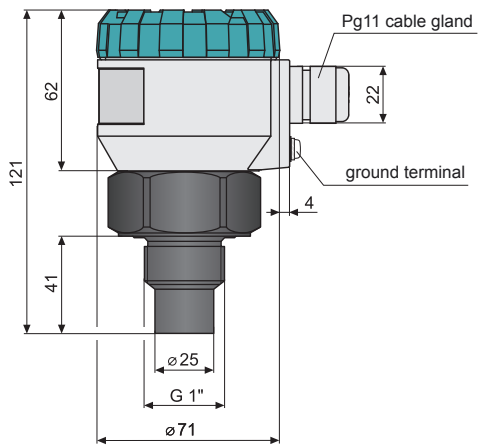

ULM-70_-06-I

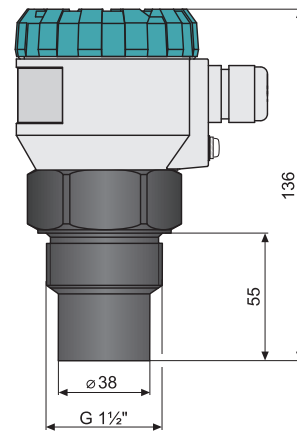

ULM-70N-10-I

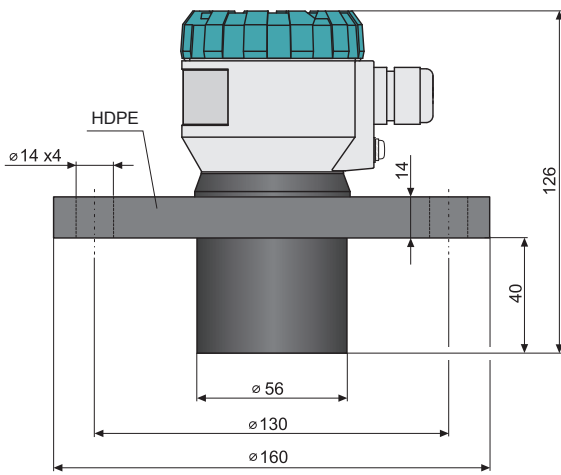

ULM-70Xi-10-I

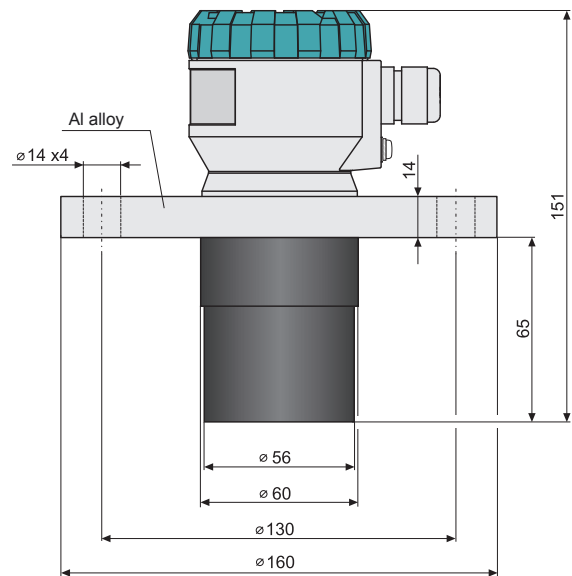

ULM-70_-20-I

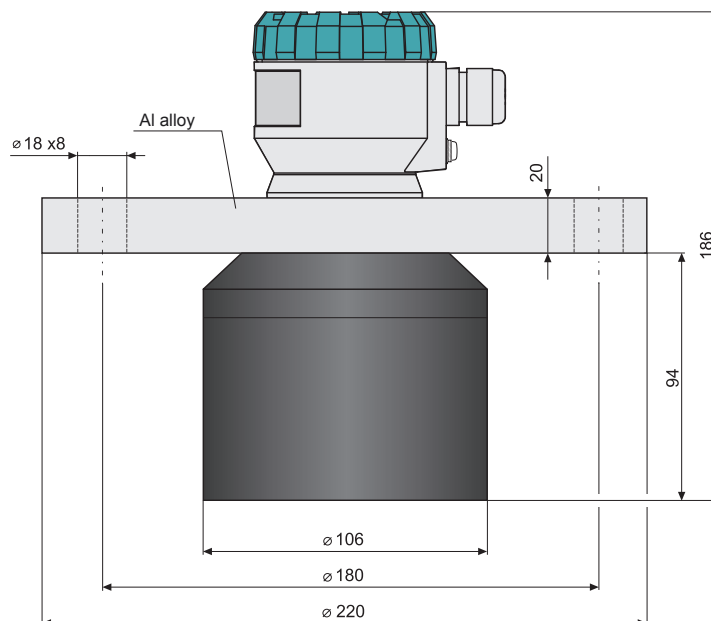

TECHNICAL SPECIFICATIONS

Measuring range ¹⁾	ULM-70_-02-I	0.2 ... 2 m
	ULM-70_-06-I	0.25 ... 6 m
	ULM-70_-10-I	0.4 ... 10 m
	ULM-70_-20-I	0.5 ... 20 m
Supply voltage	ULM-70N-_-_-I	18 ... 36 V DC
	ULM-70Xi-_-_-I	18 ... 30 V DC
Output		4 ... 20 mA (limit value 3.9 ... 20.5 mA), HART
Resolution		< 1 mm
Accuracy (within the total range)		0,15%
Temperature error		max. 0.04% / K
Beamwidth (-3 dB)	ULM-70_-02-I; 10-I	10°
	ULM-70_-06-I	14°
	ULM-70_-20-I	12°
Ambient temperature range	ULM-70_-02-I; 06-I	-30 ... +70°C
	ULM-70_-10-I; 20-I	-30 ... +60°C
Short-time temperature stress resistance		+90°C / 1 hour
Max. operation overpressure (on transmission surface)		0.1 MPa
Sensitivity		3 steps (low – medium – high)
Damping		0 ... 99 sec.
Measuring period		1 ... 4 sec.
Delay between supply power rise time and first measurement		30 sec.
Additional technical data ²⁾ (only for variant Xi) – Max. internal values		U _i =30V DC; I _i =132mA; P _i =0.99W; C _i =370nF; L _i =0.9mH
Failure indication (echo loss, level in dead zone, internal failure)		Adjustable in modes: 3.75 mA ; 22 mA ; last measured value
Protection class		IP67
Mechanical connection	ULM-70_-02-I	screwing with thread G 1"
	ULM-70_-06-I	screwing with thread G 1½"
	ULM-70N-10-I	HDPE flange
	ULM-70Xi-10-I	aluminium alloy flange
	ULM-70_-20-I	aluminium alloy flange
Recommended cable		PVC 2 x 0.75 mm ² (3 x 0.5 mm ²)
Current output load resistance (U = 24 V DC)		R _{max} = 270 Ω ³⁾
Weight	ULM-70_-02-I	0.3 kg
	ULM-70_-06-I	0.4 kg
	ULM-70N-10-I	0.7 kg
	ULM-70Xi-10-I	1.2 kg
	ULM-70_-20-I	3.1 kg

¹⁾ In case the level of bulk-solid materials is measured, the measurement range is reduced.

²⁾ Allowed temp. range in the zone 0: -20°C ... +60°C, Allowed press. range in the zone 0: 80 ... 110 kPa.

³⁾ Including 250R resistor in case of HART connection.

AREA CLASSIFICATION (according to EN 60079-10 and EN 60079-14)

ULM-70N-_-_-I	Performance for non-explosive areas
ULM-70Xi-02-I ULM-70Xi-06-I	Explosive proof – suitable for explosive areas (combustible gases or vapours) ⊕ II 1/2G Ex ia IIB T5 with isolating repeater (IRU-420) the whole level meter – zone 1, front head part – zone 0
ULM-70Xi-10-I	Explosive proof – suitable for explosive areas (combustible gases or vapours) ⊕ II 1/2G Ex ia IIB T5 with isolating repeater (IRU-420) the whole level meter – zone 1, front head part – zone 0
ULM-70Xi-20-I	Explosive proof – suitable for explosive areas (combustible gases or vapours) ⊕ II 2G Ex ia IIA T5 with isolating repeater (IRU-420) the whole level meter – zone 1

INSTALLATION

Level meter is installed into the upper lid of the tank (vessel), using a fixing nut or a flange.

If installed in an open channel (sumps, reservoirs, etc.), install the level meter as closest as you can to the maximum level expected.

The front of the level meter must be vertically to the measured level.

Foam on the level absorbs the acoustic wave reflection which might cause malfunction of the level meter. If possible select the location where the foaming is as low as possible.

Protect the level meter against direct sunlight.

In the case of uncertainty we recommend to consult the application with the producer.

MOUNTING RECOMMENDATION

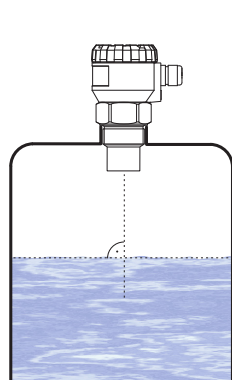

Recommended installation

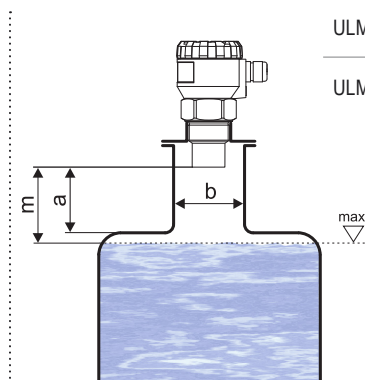

ULM-70_-02; 06-I	a < 3b b > 100 mm
ULM-70_-10-I	a < 1,5b b > 100 mm
ULM-70_-20-I	a < 1,5b b > 150 mm

a - neck height
b - neck width
m - dead zone

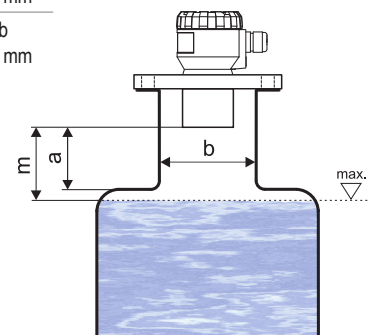

Possible installation through the neck

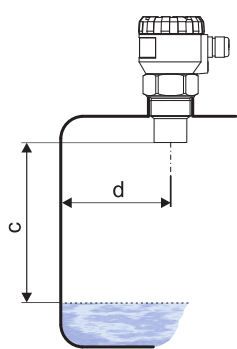

c - measuring range
d - min. distance from tank wall

ULM-70_-02; 10-I	d > 1/12 c (min. 200 mm)
ULM-70_-06-I	d > 1/8 c (min. 200 mm)
ULM-70_-20-I	d > 1/10 c (min. 200 mm)

Installation distance from the tank wall

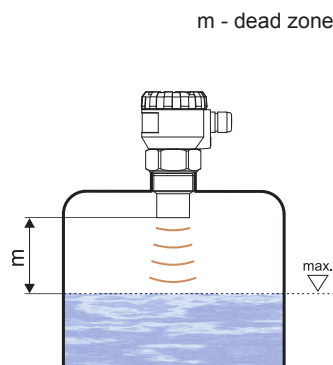

m - dead zone

Maximum level distance from ULM

ELECTRICAL CONNECTION

The ultrasonic level meter is designed to be connected to supply unit or to controller through a cable with the outer diameter of 6 ± 8 mm (recommended cross-section of cores 0.5-0.75 mm²) by means of bolted clips placed under display module. Connect the plus pole (+U) to the terminal "+", the minus pole to 0V to the terminal "-" and the shielding to the terminal "⏏" (only for shielded cables).

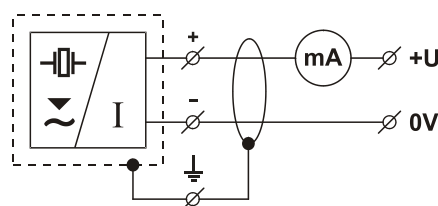

Connection diagram of the level meter

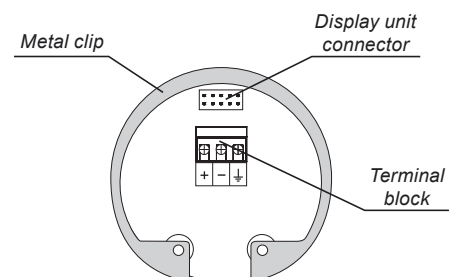

Internal view of terminal block

With regard to possible occurrence of electrostatic charge on non-conductive parts of the level meter for explosive areas (Xi version) must be **grounded** with ground terminal!

The power supply can be a stabilized voltage supply unit of 18 ÷ 36V DC (30V DC for Xi version) that is included in evaluation or display unit.

In case of strong electromagnetic interference (EMI), parallel supply cable with power lines, or when the cable length exceeds 30m, we recommend you to use a **shielded cable**.

Always **disconnect** the supply voltage before connecting the level meter!

LEVEL METER SETTING

Set the level meter using 3 buttons placed on the display module. All settings are accessible in the ULM-70 set-up mode access. For detailed information please read at the instructions manual.

button

- Set-up mode access
- Confirmation of selected item in the menu
- Saving of set-up data

button

- Move in the menu
- Change of values

button

- Cancelling of carried out changes
- Shift one level up

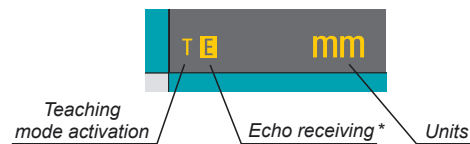
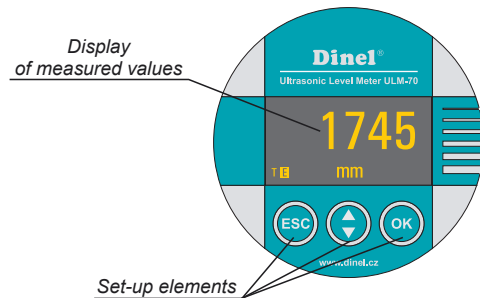

* Slow flashing while the reflected signal (echo) is received from the measured level.

RANGE OF APPLICATIONS

For continuous non-contact level measurement of liquids (water solutions, sewerage water, etc.), mash and paste materials (sediments, sticks, resins etc.) in closed or open vessels, sumps, reservoirs and open channels. In case the level of bulk-solid materials is measured, the measurement range is reduced. We recommend to consult the use with the manufacturer.

ORDER CODE

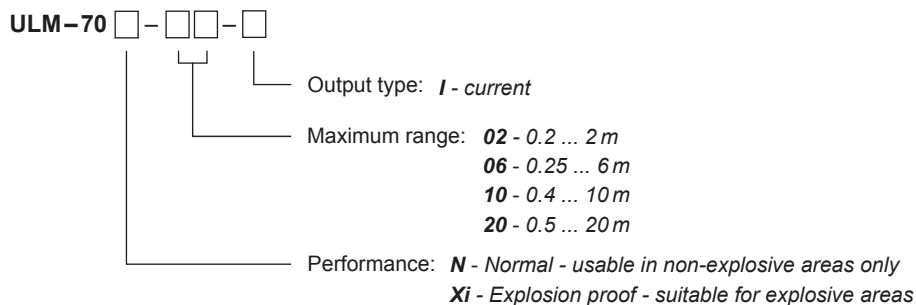

CORRECT SPECIFICATION EXAMPLES

ULM-70N-02-I
ULM-70Xi-06-I

ULM-70N-10-I
ULM-70Xi-20-I

ACCESSORIES

Standard – included in the price of the level meter

- 1x Seal (only for ULM-70_-02-I, 06-I)

Optional – for extra charge

- Stainless fixing nut UM-G1" (for ULM-70_-02-I)
- Stainless fixing nut UM-G1 ½" (for ULM-70_-06-I)

SAFETY, PROTECTION, COMPATIBILITY AND EXPLOSION PROOF

The level meter ULM-70 is equipped with protection against reverse polarity and output current overload.

Protection against dangerous contact is secured by low safety voltage that complies with EN 33 2000-4-41.

Electromagnetic compatibility according to EN 55022/B, EN 61326/Z1 and EN 61000-4-2 to 6.

Explosion proof of ULM-70Xi type complies with the following standards: EN 60079-0 : 2007; EN 60079-11 : 2007 ; EN 60079-26 : 2007 and examined by FTZÚ-AO 210 Ostrava - Radvanice certificate No.: FTZÚ 09 ATEX 0277X.

This project was realised under financial support from the funds of the state budget through the "Department of Trade and Industry".