

Amplifier Built-in Ultra-slim
Photoelectric sensor

EX-10 Series USER'S MANUAL

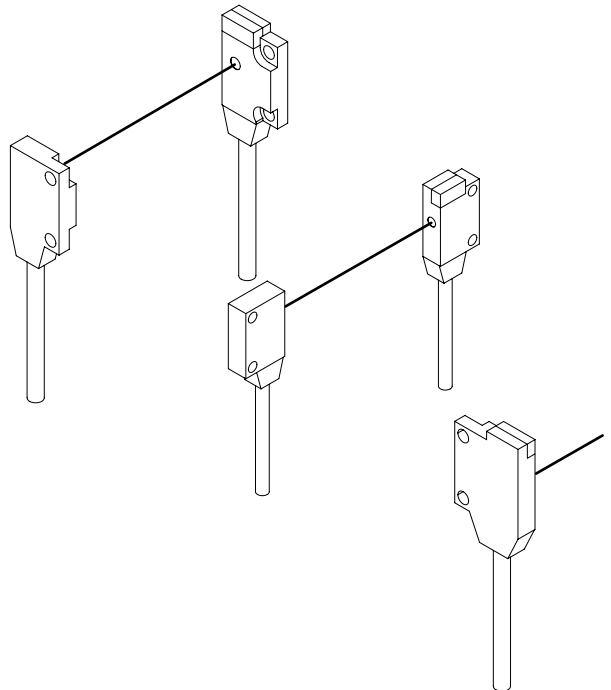

Contents

1. Safety precaution	3
2. Part Description	4
3. Mounting	6
3-1 Mounting of the sensor	6
3-2 Mounting interval	7
4. I/O Circuit Diagram	13
5. Stability Indicator	14
6. Beam alignment	14
7. Option	15
7-1 Slit Mask (optional)	15
7-2 Sensor mounting bracket (optional)	15
8. Specifications	16
8-1 Standard-beam type	16
8-2 Narrow-beam type	18
9. Dimentions	19

1. Safety precaution

WARNING

- Never use this product as a sensing device for personnel protection.
 - In case of using devices for personnel protection, use products which meet laws and standards, such as OSHA, ANSI or IEC etc., for personnel protection applicable in each region or country.
- This product has been developed / produced for industrial use only.
 - The narrow beam type **EX-1□S□** emits a narrow light beam, so it is difficult to align the beam. Use the instrument with the emitter and the receiver facing each other in a straight line. Note that if screws or other parts become loose due to vibration, for example, the beam axis may drift.
 - Sensor mounting bracket (optional) **MS-EX-10-□** is an object for standard-beam type. It cannot be used for narrow-beam type.
 - For the convergent reflective type **EX-14□**, if there is a reflective object (e.g., a conveyor, etc.) in the background of the sensing object, since it may affect the sensing, use by keeping enough distance from the reflective object.
 - The thin cable 0.1mm² is used for this product. Thus, take care that if the cable is pulled with excessive force, it may cause cable break.
 - Extension up to total 50m (each emitter and receiver of thru-beam type), or less, is possible with 0.3mm², or more of conductor area cable. However, the extension of a power supply line and the output line of less than 10m is acceptable in case using this product as conforming to S-mark.
 - Make sure that stress by forcible bend or pulling is not applied directly to the sensor cable joint.
 - Make sure to carry out wiring in the power supply off condition.
 - Take care that wrong wiring will damage the sensor.
 - Verify that the supply voltage variation is within the rating.
 - If power is supplied from a commercial switching regulator, ensure that the frame ground (F.G.) terminal of the power supply is connected to an actual ground.
 - In case noise generating equipment (switching regulator, inverter motor, etc.) is used in the vicinity of this product, connect the frame ground (F.G.) terminal of the equipment to an actual ground.
 - Do not run the wires together with high-voltage lines or power lines, or put them in the same race-way.
 - Take care that the sensor is not directly exposed to fluorescent lamp from a rapid-starter lamp, a high frequency lighting device or sunlight etc., as it may affect the sensing performance.
 - Do not use during the initial transient time (**EX-15□**, **EX-15E□**, **EX-17□**, **EX-17E□**: 100ms / others: 50ms) after the power supply is switched ON.
 - This sensor is suitable for indoor use only.
 - Do not use this sensor in places having excessive vapor, dust, etc., or where it may come in contact with corrosive gas, etc.
 - Take care that the product does not come in contact with oil, grease, organic solvents such as thinner, etc., strong acid or alkaline.
 - This product cannot be used in an environment containing inflammable or explosive gasses.
 - Never disassemble or modify the product.
 - Since the cable end is not waterproof, do not use the sensor in the application where water may seep in from the cable end.

Thru-beam front sensing type with operation mode switch on bifurcation: EX-15, EX-17

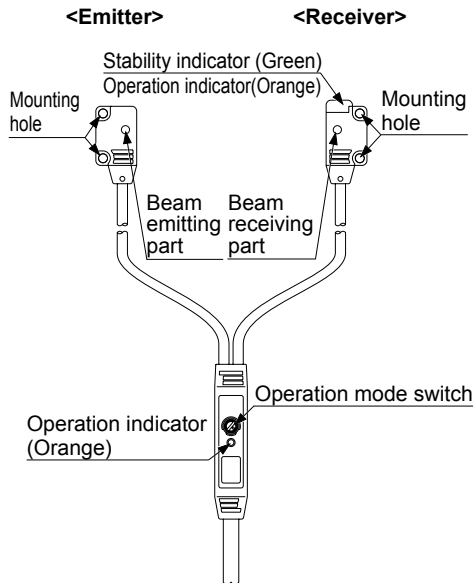

Thru-beam side sensing type with operation mode switch on bifurcation: EX-15E, EX-17E

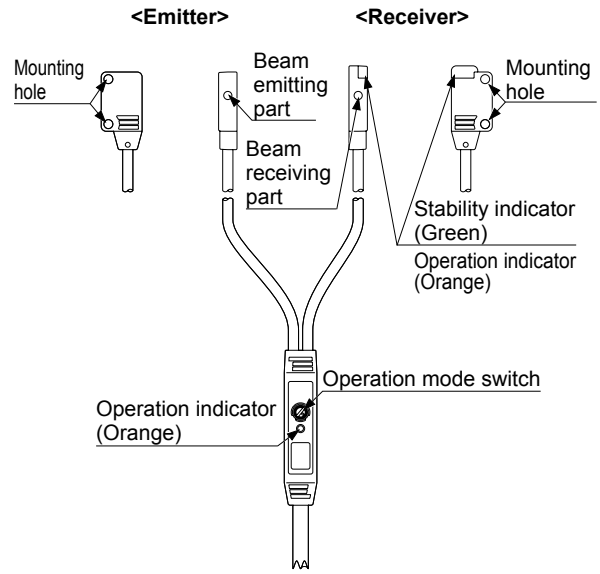

<Operation mode switch>

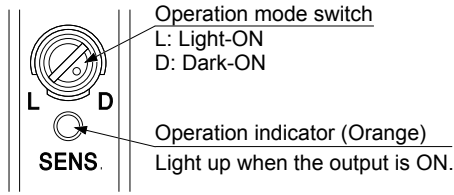

Switch position	Operation	Description
	Light-ON	Light-ON mode is set when the switch is turned fully clockwise (L side).
	Dark-ON	Dark-ON mode is set when the switch is turned fully counterclockwise (D side).

3. Mounting

3-1 Mounting of the sensor

- The tightening torque should be 0.2 N·m or less.
- The narrow beam type **EX-1□S□** emits a narrow light beam, so it is difficult to align the beam. Note that if screws or other parts become loose due to vibration, for example, the beam axis may drift.
- **In case of mounting on tapped holes (Unit: mm)**

Front sensing

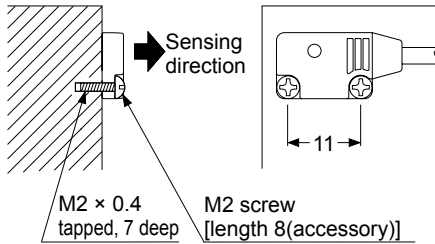

Side sensing

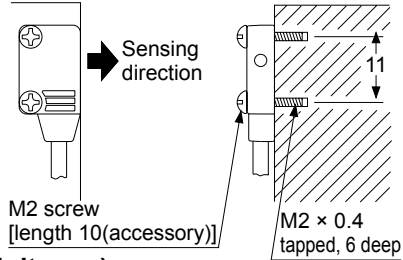

- **In case of using attached screws and nuts (Unit: mm)**

Front sensing

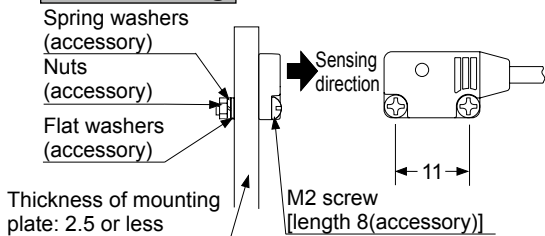

Side sensing

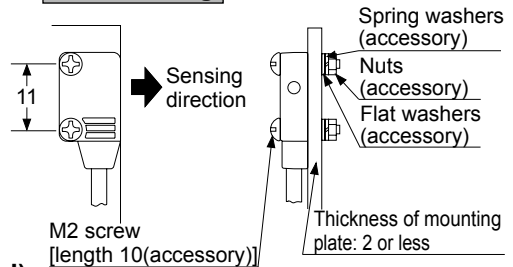

- **In case of using mounting bracket (optional)**

The sensor bracket is an object for standard-beam type. It cannot be used for narrow-beam type.

MS-EX-10-1

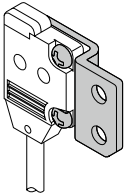

Material: SPCC (Uni-chrome plated)
Two M2 (length 4 mm) pan head screws (Accessory)

MS-EX-10-2

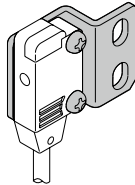

Material: SPCC (Uni-chrome plated)
Two M2 (length 8 mm) pan head screws (Accessory)

MS-EX-10-3

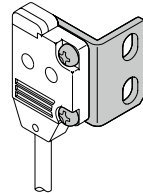

Material: SPCC (Uni-chrome plated)
Two M2 (length 4 mm) pan head screws
Two M2 (length 8 mm) pan head screws
Accessory: 2 pan head screws each

MS-EX-10-11

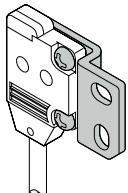

Material: SUS304
Two M2 (length 4 mm) pan head screws (Accessory)

MS-EX-10-12

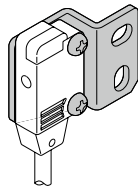

Material: SUS304
Two M2 (length 8 mm) pan head screws (Accessory)

MS-EX-10-13

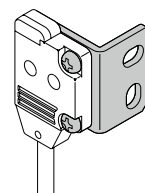

Material: SUS304
Two M2 (length 4 mm) pan head screws SUS304
Two M2 (length 8 mm) pan head screws SUS304
Accessory: 2 pan head screws each

3-2 Mounting interval

- This product does not incorporate auto interference function. In case mounting two sets or more of the this product close together, please mount them as drawing below indicates (typical example)
- Find out the operating point ℓ on the parallel deviation diagram for the setting distance L. Separate sensors by $2 \times \ell$ or more.

Thru-beam type: EX-11□, EX-15□, parallel deviation diagram (typical)

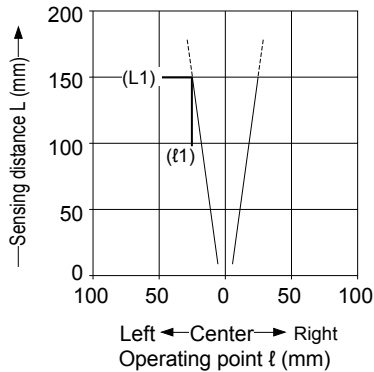

EX-11□, EX-15□: Approx. 46.8mm or more

EX-11□, EX-15□: Approx. 46.8mm or more

<Installation interval for EX-11□, EX-15□>

In case using at sensing distance (L1) 150mm, the operation point (ℓ_1) is approx. 23.4mm according to diagram above.

The installation interval is

Approx. $23.4\text{mm} \times 2 = \text{approx. } 46.8\text{mm}$

Thus, install approx. 46.8mm or more away.

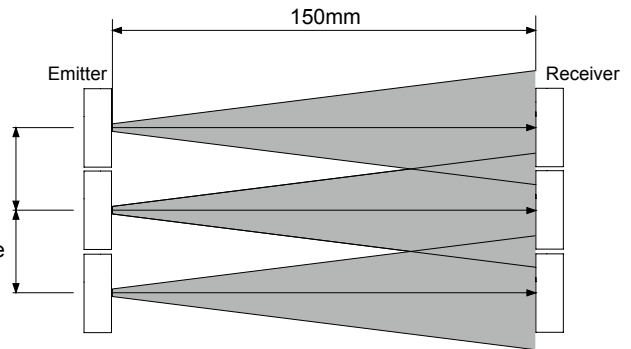

Thru-beam type: EX-11E□, EX-15E□, parallel deviation diagram (typical)

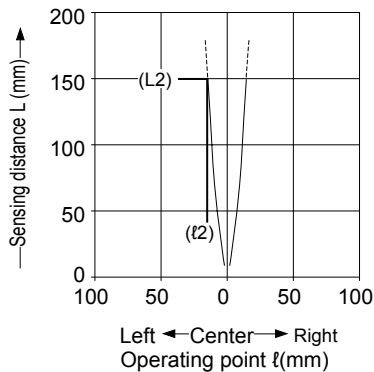

EX-11E□, EX-15E□: Approx. 30mm or more

EX-11E□, EX-15E□: Approx. 30mm or more

<Installation interval for EX-11E□, EX-15E□>

In case using at sensing distance (L2) 150mm, the operation point (ℓ_2) is approx. 15mm according to diagram above.

The installation interval is

Approx. $15\text{mm} \times 2 = \text{approx. } 30\text{mm}$

Thus, install approx. 30mm or more away.

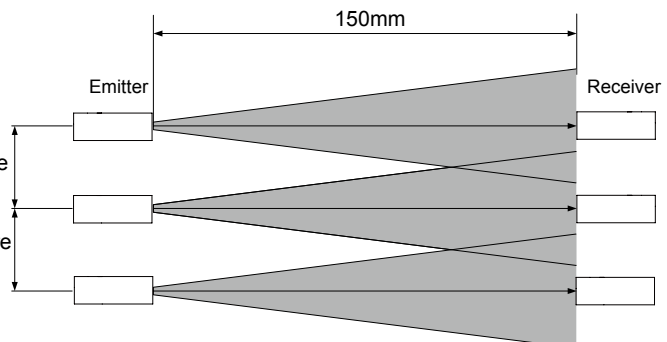

Thru-beam type: EX-13□, EX-17□ parallel deviation diagram (typical)

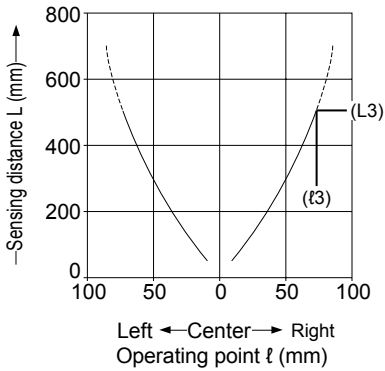

EX-13□, EX-17□ approx. 153.2mm or more

EX-13□, EX-17□ approx. 153.2mm or more

<Installation interval for EX-13□, EX-17□>

In case using at sensing distance (L3) 500mm, the operation point ($l3$) is approx. 76.6mm according to diagram above.

The installation interval is

Approx. $76.6\text{mm} \times 2 = \text{approx. } 153.2\text{mm}$

Thus, install approx. 153.2mm or more away

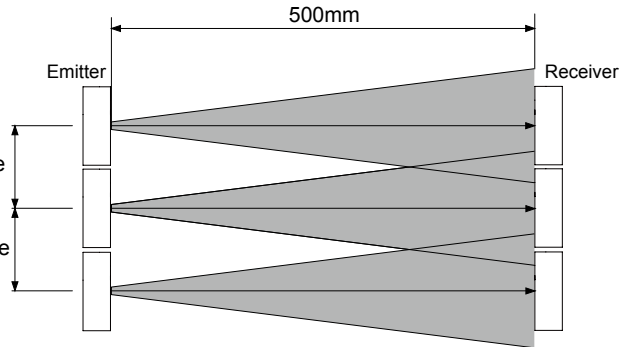

Thru-beam type: EX-13E□, EX-17E□ parallel deviation diagram (typical)

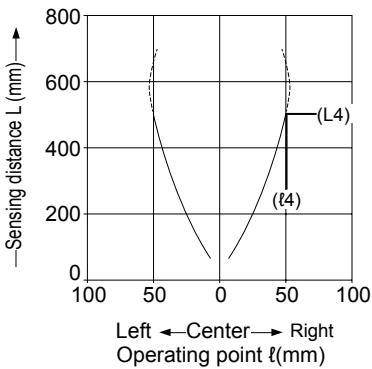

EX-13E□, EX-17E□: approx. 100mm or more

EX-13E□, EX-17E□: approx. 100mm or more

<Installation interval for EX-13E□, EX-17E□>

In case using at sensing distance (L4) 500mm, the operation point ($l4$) is approx. 50mm according to diagram above.

The installation interval is

Approx. $50\text{mm} \times 2 = \text{approx. } 100\text{mm}$

Thus, install approx. 100mm or more away.

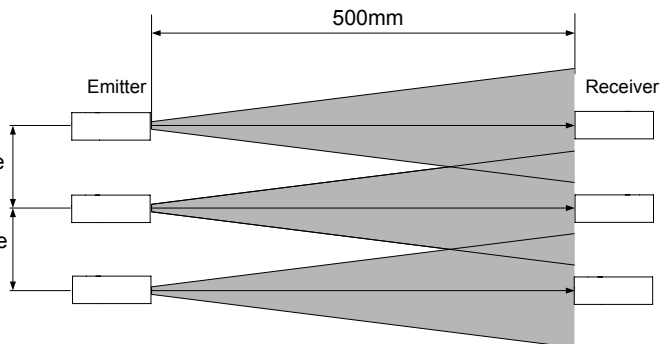

Thru-beam type: EX-19□, parallel deviation diagram (typical)

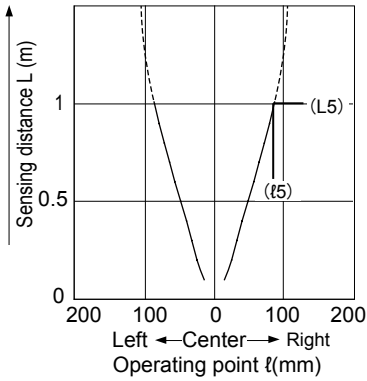

<Installation interval for EX-19□>

In case using at sensing distance (L5) 1m, the operation point (l5) is approx. 128.6mm according to diagram above.

The installation interval is

Approx. $128.6\text{mm} \times 2 = \text{approx. } 257.2\text{mm}$

Thus, install approx. 257.2 or more away.

EX-19□: approx. 257.2mm or more

EX-19□: approx. 257.2mm or more

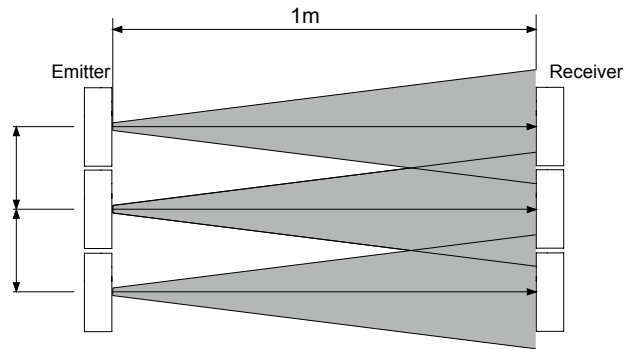

Thru-beam type: EX-19E□, parallel deviation diagram (typical)

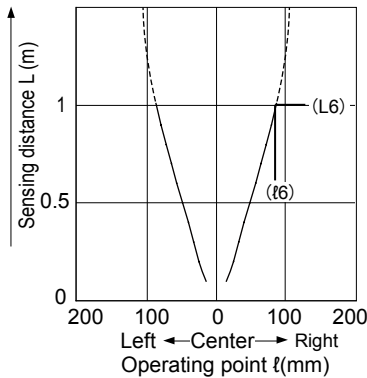

<Installation interval for EX-19E□>

In case using at sensing distance (L6) 1m, the operation point (l6) is approx. 71.1mm according to diagram above.

The installation interval is

Approx. $71.1\text{mm} \times 2 = \text{approx. } 142.2\text{mm}$

Thus, install approx. 142.2 or more away.

EX-19E□ : approx. 142.2mm or more

EX-19E□ : approx. 142.2mm or more

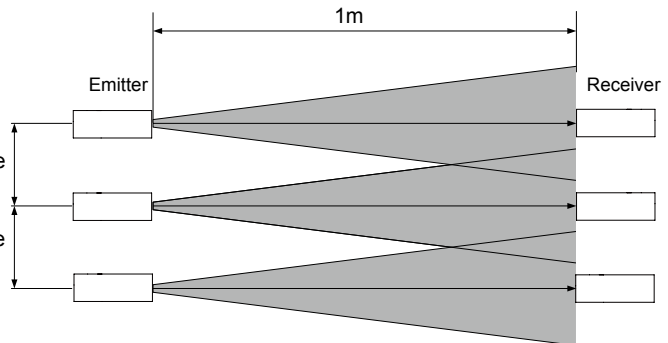

Thru-beam type: EX-11S□, parallel deviation diagram (typical)

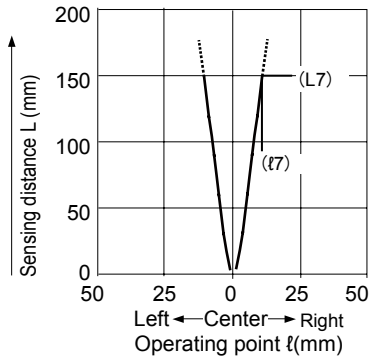

<Installation interval for EX-11S□>

In case using at sensing distance (L7) 150mm, the operation point (ℓ7) is approx. 10.8mm according to diagram above.

The installation interval is

Approx. $10.8\text{mm} \times 2 = \text{approx. } 21.6\text{mm}$

Thus, install approx. 21.6 or more away.

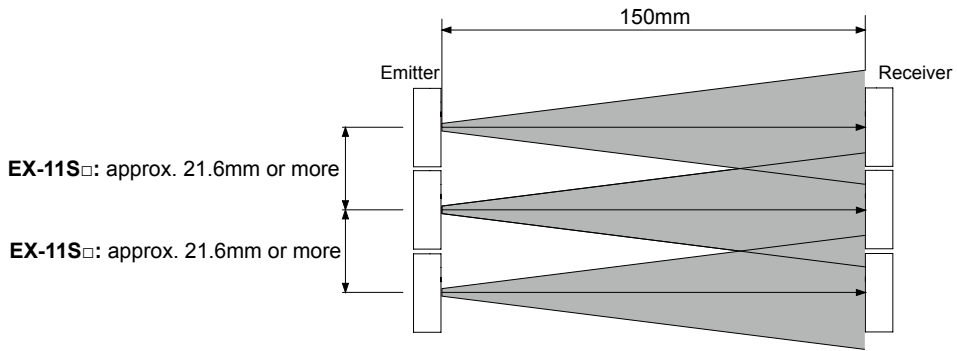

Thru-beam type: EX-11SE□, parallel deviation diagram (typical)

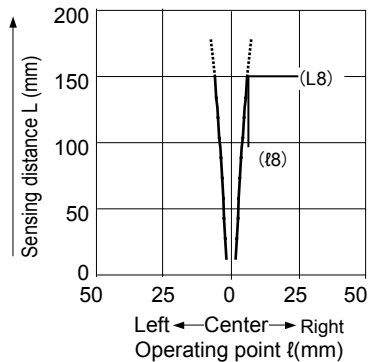

<Installation interval for EX-11SE□>

In case using at sensing distance (L8) 150mm, the operation point (ℓ8) is approx. 6.2mm according to diagram above.

The installation interval is

Approx. $6.2\text{mm} \times 2 = \text{approx. } 12.4\text{mm}$

Thus, install approx. 12.4 or more away.

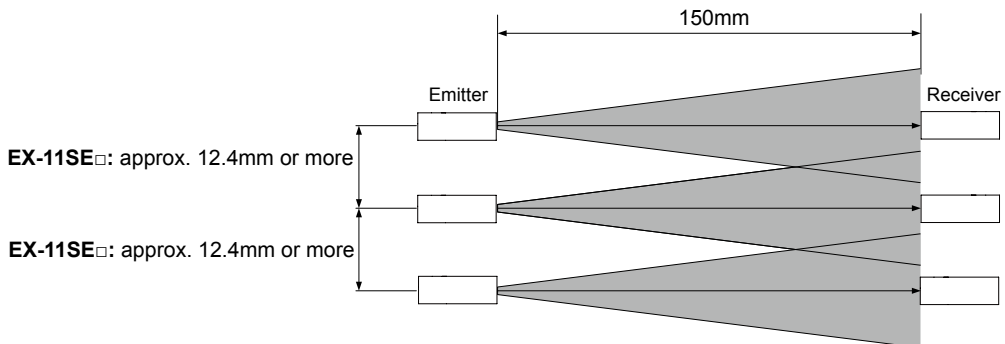

Thru-beam type: EX-13S□, parallel deviation diagram (typical)

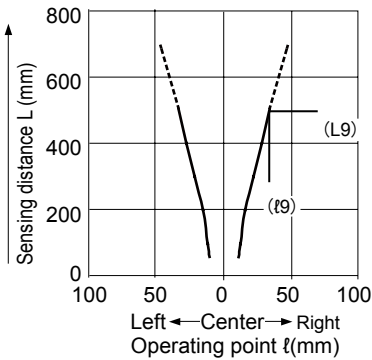

<Installation interval for **EX-13S□**>

In case using at sensing distance (L9) 500mm, the operation point (l9) is approx. 37.1mm according to diagram above.

The installation interval is

Approx. 37.1mm × 2 = approx. 74.2mm

Thus, install approx.74.2 or more away.

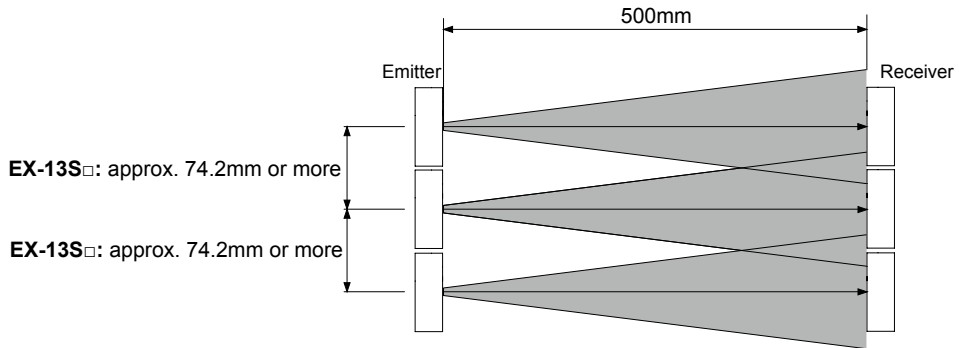

Thru-beam type: EX-13SE□, parallel deviation diagram (typical)

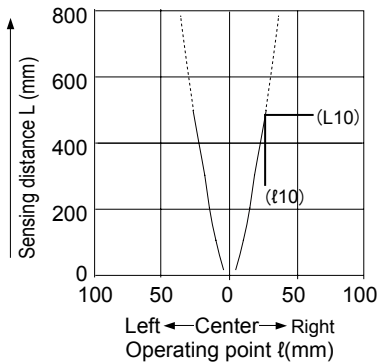

<Installation interval for **EX-13SE□**>

In case using at sensing distance (L10) 500mm, the operation point (l10) is approx. 29.2mm according to diagram above.

The installation interval is

Approx. 29.2mm × 2 = approx. 58.4mm

Thus, install approx.58.4 or more away.

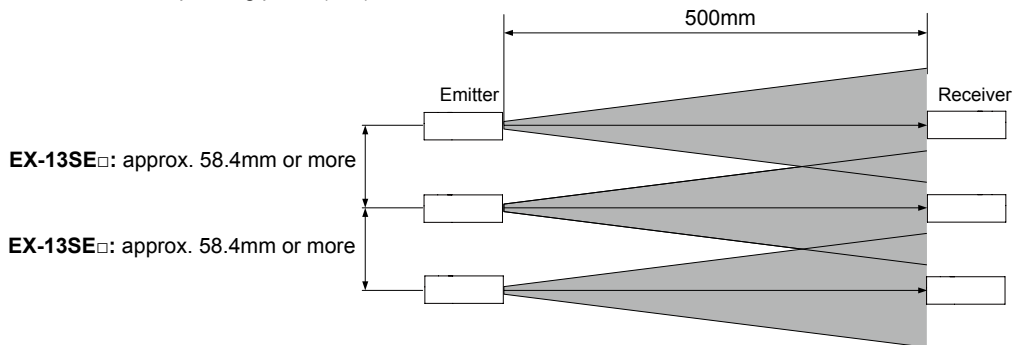

Thru-beam type: EX-19S□, parallel deviation diagram (typical)

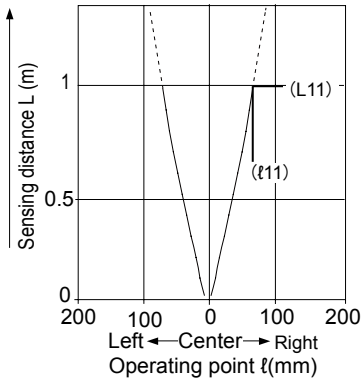

<Installation interval for EX-19S□>

In case using at sensing distance (L11) 1m, the operation point (l11) is approx. 65.4mm according to diagram above.

The installation interval is
 Approx. 65.4mm × 2 = approx. 130.8mm
 Thus, install approx. 130.8 or more away.

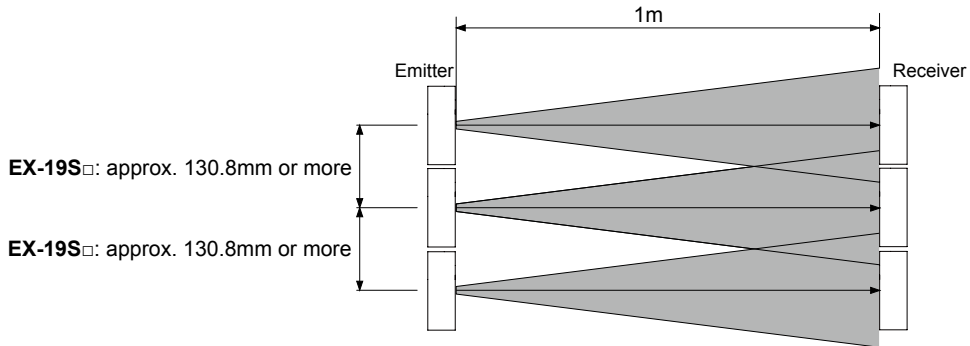

4. I/O Circuit Diagram

EX-11□, EX-13□, EX-19□, EX-14□

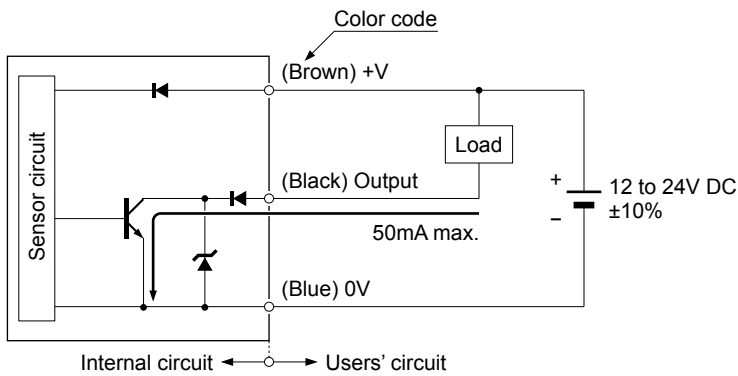

Note: The thru-beam type sensor emitter does not incorporate the output..

EX-11□-PN, EX-13□-PN, EX-19□-PN, EX-14□-PN

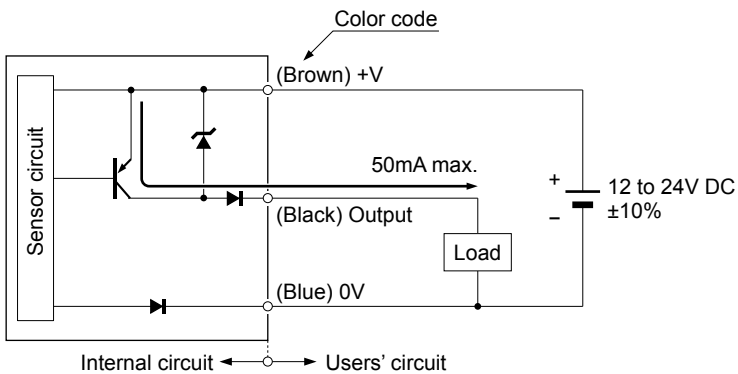

Note: The thru-beam type sensor emitter does not incorporate the output..

EX-15□, EX-17□

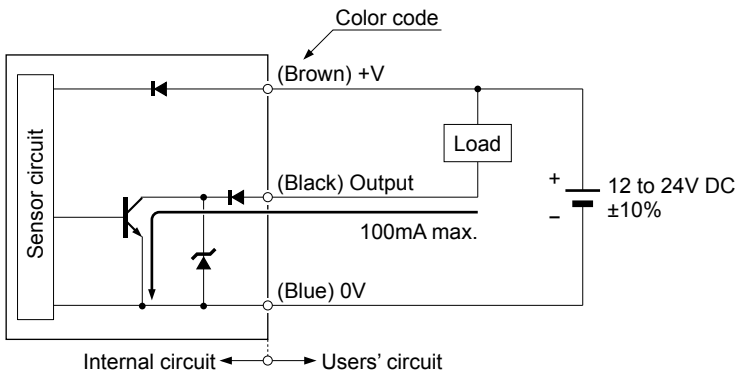

5. Stability Indicator

- The stability indicator (green) lights up when the incident light intensity has sufficient margin with respect to the operation level. Incident light intensity level is such that the stability indicator light up, stable sensing can be done without the light received operation and the light interrupted operation being affected by a change in ambient temperature or supply voltage.

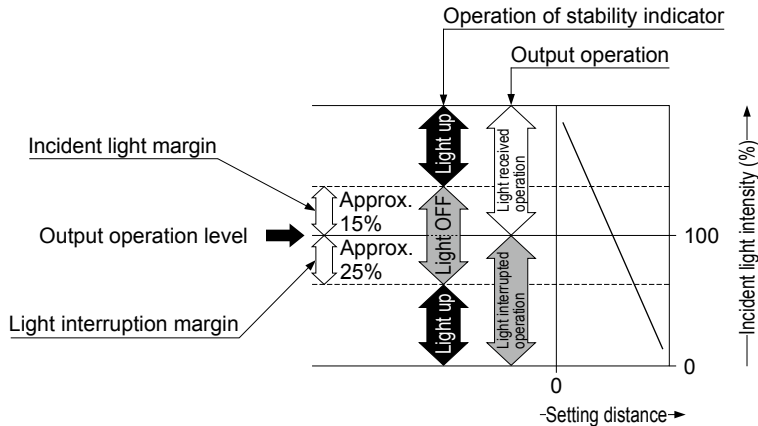

6. Beam alignment

Thru-beam type: EX-11□, EX-13□, EX-19□, EX-15□, EX-17□
EX-11S□, EX-13S□, EX-19S□

- Place the emitter and the receiver face to face along a straight line, move the emitter in the up, down, left and right directions, in order to determine the range of the light received condition with the help of the operation indicator (orange). Then, set the emitter at the center of this range.(Note 1)
- Similarly, adjust for up, down, left and right angular movement of the emitter.
- Further, perform the angular adjustment for the receiver also.
- Check that the stability indicator (green) lights up. (Note 2)

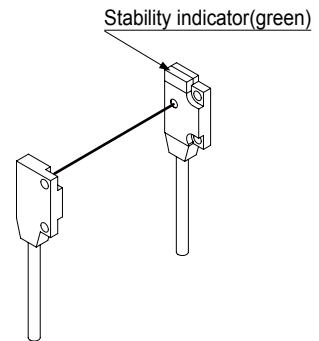

(Note1) : When using the narrow beam type EX-1□S□, if the beam axes are out of alignment, check to see if the emitter and the receiver are facing each other in a straight line.
 (Note2) : In case of EX-15 / 17, adjust the beam axis after turn the operation mode switch to "L-ON". After it, switch the operation mode by adopting the operation.

7. Option

7-1 Slit Mask (optional)

- Apply the optional slit mask **OS-EX10-□** when detecting small objects or for increasing the accuracy of sensing position.
However, the sensing range is reduced when the slit mask is mounted.

Type	Model No.		Slit size	Sensing distance		Minimal sensing object	
	Slit	Sensor		Applying on one side	Applying on both side	Applying on one side	Applying on both side
Slit	OS-EX10-12	EX-19□	ø1.2mm	600mm	400mm	ø2mm	ø1.2mm
		EX-13□ EX-17□		250mm	200mm	ø2mm	ø1.2mm
	OS-EX10-15	EX-19□	ø1.5mm	800mm	500mm	ø2mm	ø1.5mm
		EX-13□		350mm	300mm	ø2mm	ø1.5mm
	OS-EX10E-12	EX-13E□ EX-17E□	ø1.2mm	250mm	200mm	ø2mm	ø1.2mm

OS-EX10-12
OS-EX10-15

OS-EX10E-12

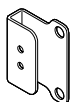

Mounting method

1. Insert the sensor into the slit.
2. Mount it to mounting plate. Make sure that the tightening torque is 0.2N·m or less.

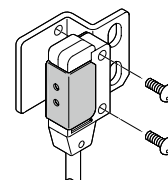

Tightening together with mounting plate

7-2 Sensor mounting bracket (optional)

- The sensor bracket is an object for standard-beam type. It cannot be used for narrow-beam type.

Type	Model No.	Description
Sensor mounting bracket	MS-EX10-1	For front sensing type (Thru-beam type needs 2 sets.) Material : SPCC(Uni-chrome plated) · Two M2 (length 4mm) pan head screw are attached.
	MS-EX10-2	For Side sensing type (Thru-beam type needs 2 sets.) Material : SPCC(Uni-chrome plated) · Two M2 (length 8mm) pan head screw are attached.
	MS-EX10-3	L-form mouting bracket (Thru-beam type needs 2 sets.) Material : SPCC(Uni-chrome plated) · Two M2 (length 4mm) and Two M2 (length 8mm) pan head screw are attached.
	MS-EX10-11	For front sensing type (Thru-beam type needs 2 sets.) Material : SUS304 · Two M2 (length 4mm) pan head screw are attached.
	MS-EX10-12	For Side sensing type (Thru-beam type needs 2 sets.) Material : SUS304 · Two M2 (length 8mm) pan head screw are attached.
	MS-EX10-13	L-form mouting bracket (Thru-beam type needs 2 sets.) Material : SUS304 · Two M2 (length 4mm) and Two M2 (length 8mm) pan head screw are attached.

(Note) : Regarding the mounting image, refer to P6. Regarding the external dimensions, refer to P23 & 24.

8. Specifications

8-1 Standard-beam type

Type		Thru-beam type						Convergent reflective (Diffused beam type)	
		Front sensing	Side sensing	Front sensing	Side sensing	Front sensing	Side sensing	Front sensing	
Model No (Note 2)	Light-ON	EX-11A (-PN)	EX-11EA (-PN)	EX-13A (-PN)	EX-13EA (-PN)	EX-19A (-PN)	EX-19EA (-PN)	EX-14A (-PN)	
	Dark-ON	EX-11B (-PN)	EX-11EB (-PN)	EX-13B (-PN)	EX-13EB (-PN)	EX-19B (-PN)	EX-19EB (-PN)	EX-14B (-PN)	
Sensing range		150mm		500mm		1m		2 to 25mm (Note 3) (Center 10mm)	
Minimum sensing object		ø1mm opaque object (Completely beam interrupted object) (Setting distance between emitter and receiver: 150mm)		ø2mm opaque object (Completely beam interrupted object) (Setting distance between emitter and receiver: 500mm)		ø2mm opaque object (Completely beam interrupted object) (Setting distance between emitter and receiver: 1m)		ø0.1mm copper wire (Setting distance: 10mm)	
Hysteresis		—						15 % or less of operation distance (Note 3)	
Repeatability (Perpendicular to sensing axis)		0.05mm or less						0.1mm or less	
Supply voltage		12 to 24V DC ±10% Ripple P-P 10% or less							
Current consumption		Emitter: 10mA or less, Receiver: 10mA or less						13mA or less	
Output		<NPN output type> NPN open-collector transistor <ul style="list-style-type: none"> • Maximum sink current: 50mA • Applied voltage: 30 V DC or less (between output and 0V) • Residual voltage: 2V or less (at 50mA sink current) 1V or less (at 16mA sink current) 			<PNP output type> PNP open-collector transistor <ul style="list-style-type: none"> • Maximum source current: 50mA • Applied voltage: 30 V DC or less (between output and +V) • Residual voltage: 2V or less (at 50mA source current) 1V or less (at 16mA source current) 				
Short-circuit protection		Incorporated							
Response time		0.5 ms or less							
Protection		IP67 (IEC)							
Ambient temperature		-25 to +55°C (No dew condensation or icing allowed), Storage: -30 to +70°C							
Ambient humidity		35 to 85 % RH, Storage: 35 to 85% RH							
Emitting element		Red LED (Peak emission wavelength : EX-19E=624nm, except EX-19E= 680nm, modulated)							
Material		Enclosure: Polyallylate, Lens: Polyallylate							
Cable (Note 4)		0.1mm ² 3-core (thru-beam type emitter: 2-core) cabtyre cable, 2 m long							
Weight	Net weight	Emitter, receiver: Approx. 20 g each(-C5 type : Approx.50 g each)						Approx.20g (-C5 type : Approx 50g)	
	Gross weight	Approx.50g(-C5 type : Approx.110 g)						Approx.30g (-C5 type : Approx 60g)	
Accessories		Mounting screws: 1 set, Instruction Manual							

Type	Thru-beam · with operation mode switch on bifurcation			
	Front sensing	Side sensing	Front sensing	Side sensing
Model No. (Note 2)	EX-15 (Note 5)	EX-15E	EX-17	EX-17E
Sensing range	150mm		500mm	
Minimum sensing object	ø1 mm opaque object (Completely beam interrupted object) (Setting distance between emitter and receiver: 150mm)		ø2 mm opaque object (Completely beam interrupted object) (Setting distance between emitter and receiver: 500mm)	
Hysteresis	-			
Repeatability Perpendicular to sensing axis	0.05mm or less			
Supply voltage	12 to 24 V DC ±10 % Ripple P-P10 % or less			
Current consumption	25mA or less			
Output	NPN open-collector transistor <ul style="list-style-type: none"> • Maximum sink current: 100 mA • Applied voltage: 30V DC or less (between output and 0 V) Residual voltage: 2V or less (at 100mA sink current) 1V or less (at 16mA sink current) 			
Short-circuit protection	Incorporated			
Response time	0.5ms or less			
Protection	- IP67 (IEC)			
Ambient temperature	-25 to +55°C (No dew condensation or icing allowed), Storage: -30 to +70°C			
Ambient humidity	35 to 85% RH, Storage: 35 to 85% RH			
Emitting element	Red LED (Peak emission wavelength: 680nm, modulated)			
Material	Enclosure: Polyethylene terephthalate, Lens: Polyallylate, Bifurcation: Polyallylate			
Cable	0.2 mm ² 3-core cabtyre cable, 2m long (beyond bifurcation; from emitter / receiver to bifurcation: 0.5m long)			
Wight	Net weight	55g approx		
	Gross weight	80g approx.		
Accessory	Mounting screws: 1 set, Adjusting screwdriver: 1 pc, Instruction Manual			

8-2 Narrow-beam type

Type		Thru-beam type					
		Front sensing	Side sensing	Front sensing	Side sensing	Front sensing	
Model No (Note 2)	Light-ON	EX-11SA (-PN)	EX-11SEA (-PN)	EX-13SA (-PN)	EX-13SEA (-PN)	EX-19SA (-PN)	
	Dark-ON	EX-11SB (-PN)	EX-11SEB (-PN)	EX-13SB (-PN)	EX-13SEB (-PN)	EX-19SB (-PN)	
Sensing range		150mm		500mm		1m	
Minimum sensing object		ø0.5mm opaque object (Completely beam interrupted object) (Setting distance between emitter and receiver: 150mm)	ø1mm opaque object (Completely beam interrupted object) (Setting distance between emitter and receiver: 150mm)	ø1mm opaque object (Completely beam interrupted object) (Setting distance between emitter and receiver: 500mm)	ø2mm opaque object (Completely beam interrupted object) (Setting distance between emitter and receiver: 500mm)	ø2mm opaque object (Completely beam interrupted object) (Setting distance between emitter and receiver: 1m)	
Hysteresis		—					
Repeatability (Perpendicular to sensing axis)		0.05mm or less					
Supply voltage		12 to 24V DC ±10% Ripple P-P 10% or less					
Current consumption		Emitter: 10mA or less, Receiver: 10mA or less					
Output		<NPN output type> NPN open-collector transistor <ul style="list-style-type: none"> • Maximum sink current: 50mA • Applied voltage: 30 V DC or less (between output and 0V) • Residual voltage: 2V or less (at 50mA sink current) 1V or less (at 16mA sink current) 			<PNP output type> PNP open-collector transistor <ul style="list-style-type: none"> • Maximum source current: 50mA • Applied voltage: 30 V DC or less (between output and +V) • Residual voltage: 2V or less (at 50mA source current) 1V or less (at 16mA source current) 		
		Short-circuit protection		Incorporated			
Response time		0.5 ms or less					
Protection		IP67 (IEC)					
Ambient temperature		-25 to +55°C (No dew condensation or icing allowed), Storage: -30 to +70°C					
Ambient humidity		35 to 85 % RH, Storage: 35 to 85% RH					
Emitting element		Red LED (Peak emission wavelength : 650nm, modulated)					
Material		Enclosure: Polyallylate, Lens: Polyallylate					
Cable (Note 4)		0.1mm ² 3-core (thru-beam type emitter: 2-core) cabtyre cable, 2 m long					
Weight	Net weight	Emitter, receiver: Approx. 20 g each					
	Gross weight	Approx. 50g					
Accessories		Mounting screws: 1 set, Instruction Manual					

- Notes:
- 1) Where measurement conditions have not been specified precisely, the conditions used were an ambient temperature of +23°C.
 - 2) The model No. with suffix "P" shown on the label affixed to the thru-beam type sensor is the emitter, "D" shown on the label is the receiver.
 (EX) Emitter of **EX-11A**: **EX-11P**, Receiver of **EX-11A**: **EX-11AD**
 Model Nos. having suffix "-R" are inflection resistant cable type. (except PNP output type, Narrow-beam type and Thru-beam type with operation mode switch on bifurcation **EX-15□ / 17□**)
 (EX) **EX-11A** of inflection resistant cable type is "**EX-11A-R**"
 Model Nos. having the suffix "-C5" are 5m cable length type. (except PNP output type, Narrow-beam type and inflection resistant cable type)
 (EX) **EX-11A** of 5m cable length type is "**EX-11A-C5**"
 - 3) The sensing range and the hysteresis of convergent reflective type sensor are specified for white non-glossy paper (50 × 50 mm) as the object.
 - 4) The inflection resistant type (having suffix "-R" at end of model No.) has a 0.1mm² 3-core (thru-beam type emitter: 2-core) inflection resistant cabtyre cable, 2m long.
 - 5) Either Light-ON or Dark-ON can be selected by the operation mode switch (located on the bifurcation).

9. Dimentions

Thru-beam front sensing type: EX-11□, EX-13□, EX-19□, EX-11S□, EX-13S□, EX-19S□

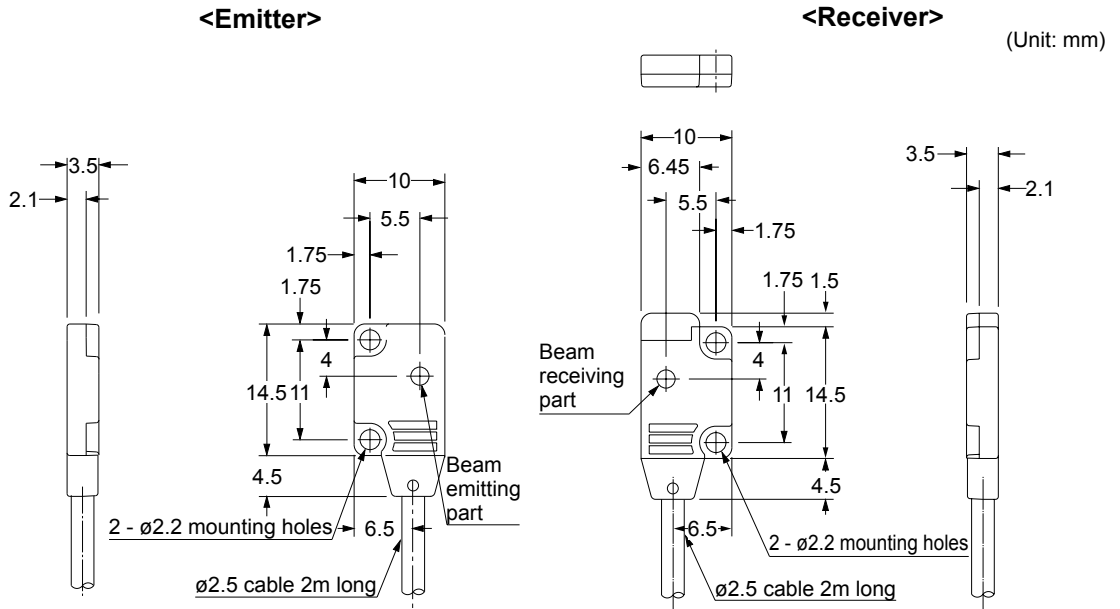

Thru-beam side sensing type: EX-11E□, EX-13E□, EX-19E□, EX-11SE□, EX-13SE□

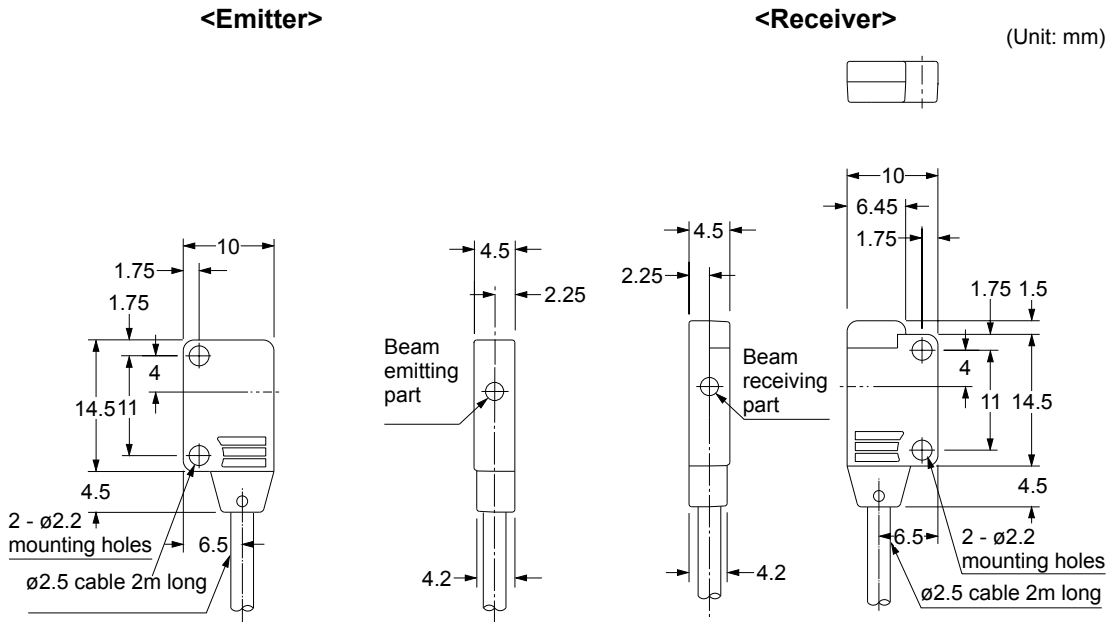

Thru-beam front sensing type with operation mode switch on bifurcation: EX-15, EX-17

<Emitter>

<Receiver>

(Unit: mm)

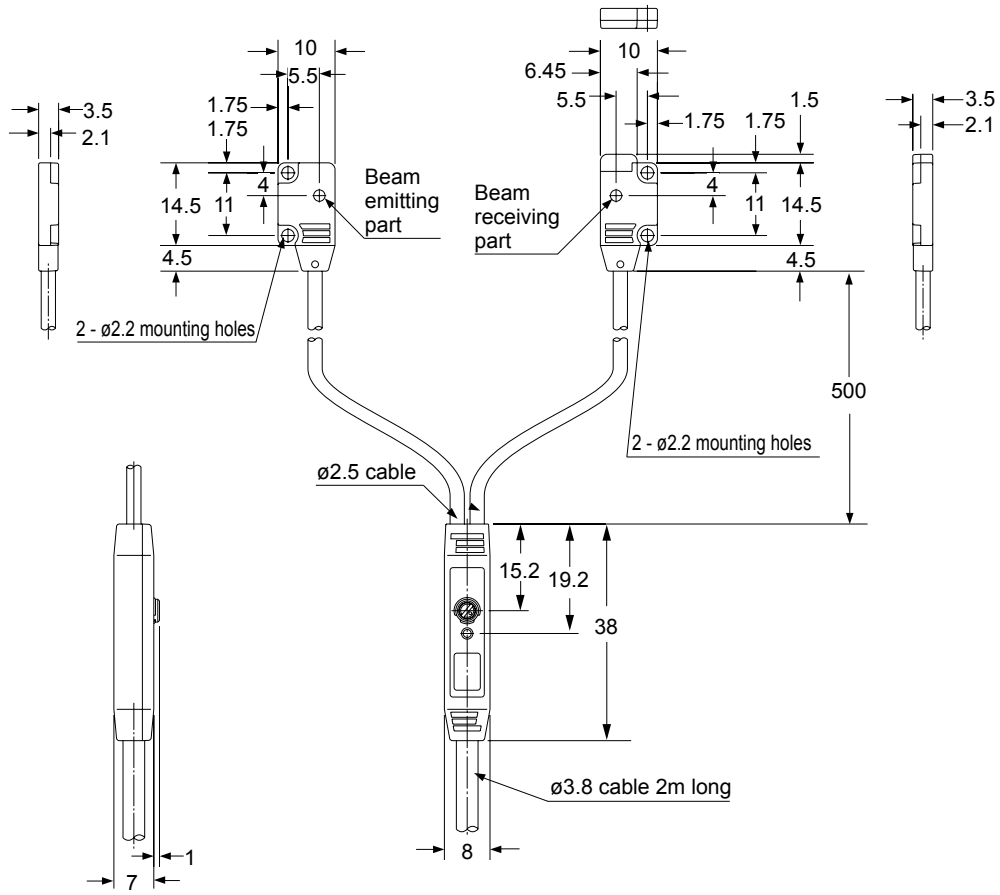

Thru-beam side sensing type with operation mode switch on bifurcation: EX-15E, EX-17E

<Emitter>

<Receiver>

(Unit: mm)

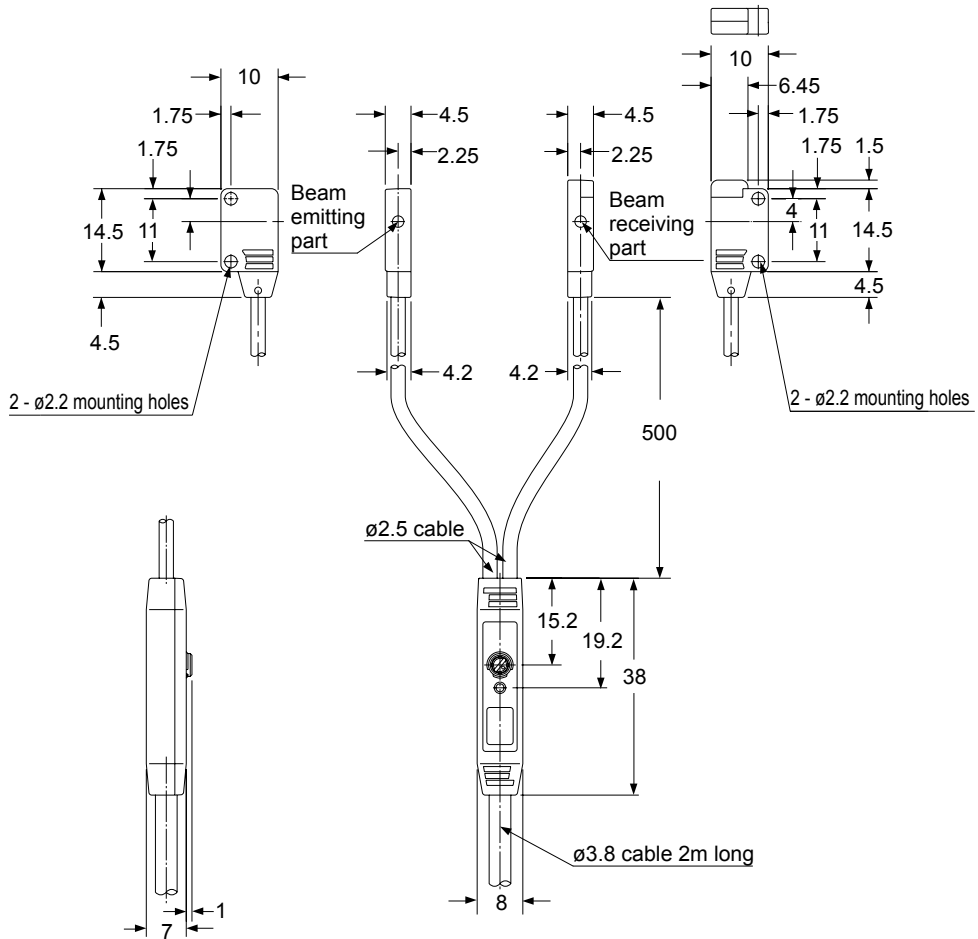

Convergent reflective: EX-14□

(Unit: mm)

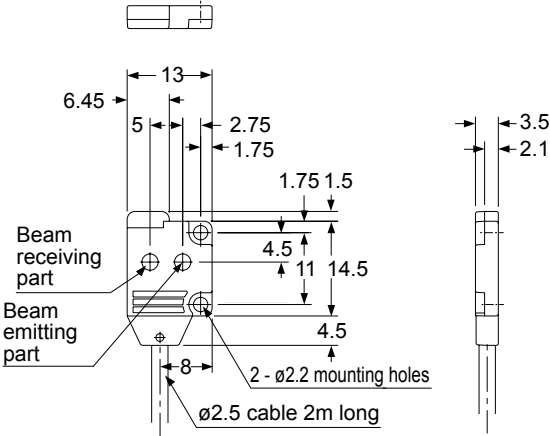

Mounting bracket: MS-EX10-1

(Unit: mm)

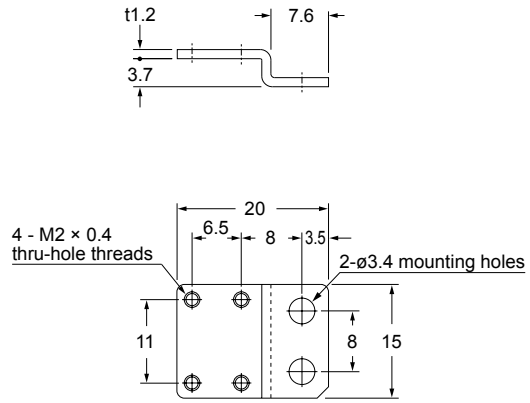

Mounting bracket: MS-EX10-2

(Unit: mm)

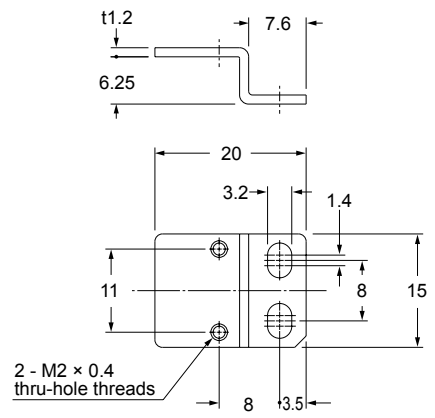

Mounting bracket: MS-EX10-3

(Unit: mm)

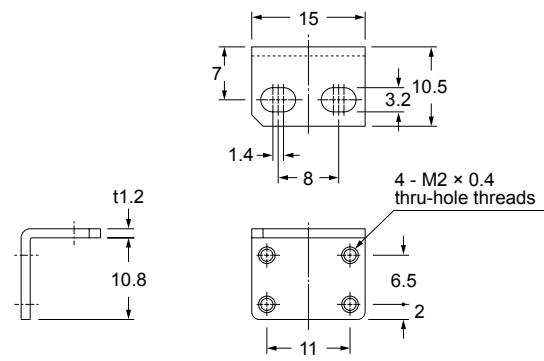

(Note):The sensor bracket is an object for satandard-beam type. It cannot be used for narrow-beam type.

Mounting bracket: MS-EX10-11

(Unit: mm)

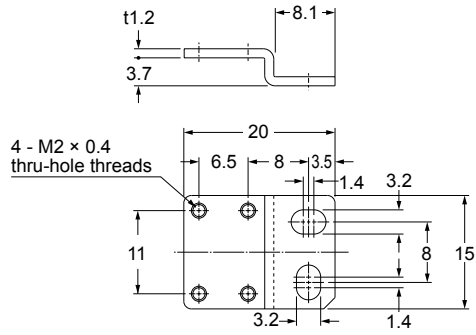

Mounting bracket: MS-EX10-12

(Unit: mm)

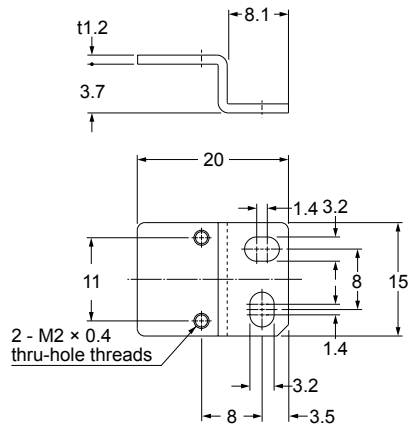

Mounting bracket: MS-EX10-13

(Unit: mm)

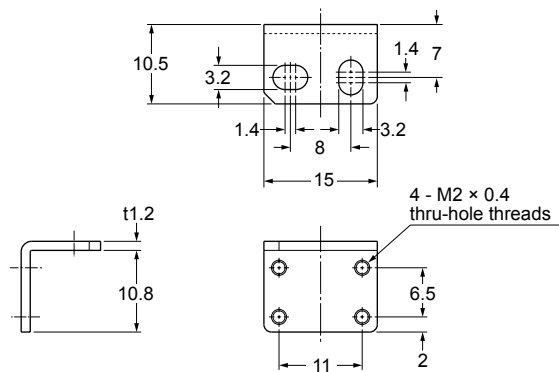

(Note):The sensor bracket is an object for satandard-beam type. It cannot be used for narrow-beam type.

Please contact

Panasonic Industrial Devices SUNX Co., Ltd.

<http://panasonic.net/id/pidsx/global>

Overseas Sales Division (Head Office)

2431-1 Ushiyama-cho, Kasugai-shi, Aichi, 486-0901, Japan

Phone: +81-568-33-7861 FAX: +81-568-33-8591

About our sale network, please visit our website.

© Panasonic Industrial Devices SUNX Co., Ltd. 2013

October, 2013 PRINTED IN JAPAN

WUME-EX10-4